



Illustrated Parts List

AXIP0300

November 2006

DST40(P), DST41(P), DDT40(P), DDT41(P)
RST40, RST41

TABLE OF CONTENTS

Models 2

General Information 3

 How To Use Illustrated Parts List.....3

 Model & Component Identification4

Forward Axle Parts Explode 6

Forward Axle Parts List 8

Wheel Differential Lock Assembly 11

Rear Axle Parts Explode 12

Rear Axle Parts List 13

Bearing Spacers 15

 DST/DDT40(P), DST/DDT41(P) 15

 RST40, RST41 15

Output Shaft & Axle Housing Parts Explode 16

Output Shaft & Axle Housing Parts List 17

Axle Housing Hardware 18

 DST/DDT40(P), DST/DDT41(P)..... 18

 RST40, RST41 19

Axle Shafts 20

 Axle Shaft Hardware 21

Gear & Pinion Kits 22

 DST40(P), DST41(P), DDT40(P), DDT41(P)..... 22

 RST40, RST41 23

Service Carriers - Single Reduction 24

 DST40(P), DST41(P) 24

 DST40(P), DST41(P) with No Spin 24

 DDT40(P), DDT41(P) 24

 RST40, RST41 24

Yokes & Flanges 25

Oil Seal Installation Tools 26

Kits and Assemblies 27

Models

The following models are represented in this publication.

Single Reduction Models

Forward Axle	Rear Axle	Axle Capacity	Gear Size
DST40(P)	RST40	40,000 Lbs	15.40"/16.50"
DST41(P)	RST41	40,000 Lbs	15.40"/16.50"

Single Reduction Models W/Wheel Differential Lock

Forward Axle	Rear Axle	Axle Capacity	Gear Size
DDT40(P)	NA	40,000 Lbs	15.40"/16.50"
DDT41(P)	NA	40,000 Lbs	15.40"/16.50"

General Information

How To Use Illustrated Parts List

Ordering Parts

- This parts book is organized in sections according to parts servicing requirements. Use the Contents or page headings and colored tabs to find information.
- Use this book to order parts for your Spicer® Axle.
- For convenience, part numbers have been included for all pieces of the carrier assembly. Some of these parts, such as the carrier and caps, are serviced only in kits or assemblies. Part numbers are for your reference only. Those parts not serviced separately are identified with NSS.

Kits and Assemblies

- Kits and Assemblies contain groups of individual or assembled parts developed for optimal replacement or repair of a service problem.
- Kits and Assemblies are shown with applicable parts groupings in the parts listing.
- See the Appendix for detailed information concerning kits applicable to this model.

Abbreviations

- **AR - As Required** - Parts that vary in quantity with each axle. Example: shims
- **NSS - Not Serviced Separately** - Items which can only be purchased in sets, kit form or service assemblies. Example: brake shoes.
- **RH/LH - Right Hand/Left Hand** - Determined as viewed from behind the vehicle looking forward.
- **“RTV” - Gasket Compound** - Formed-in-place gasket sealer. It is recommended for use on all surfaces requiring a gasket.
- **Assy - Assembly**

- **Brg - Bearing**
- **Diff - Differential**
- **Hsg - Housing**
- **Inv- Involute**
- **IASS - In Axle Speed Sensor**
- **ABS - Antilock Brake System**
- **N/A - Not Applicable**
- **Str- Straight**

Illustrations

- Illustrations show parts in assembly groups.
- Item numbers on illustrations correspond with parts listings on pages that accompany the drawings.
- Notes are included on illustrations where needed.

Parts Listings

- Parts listings are defined by parts groupings and are broken down by service assemblies.
- Parts Listings identify a part for servicing with the following categories:
 - **Item** - corresponds with numbers on illustrations for part identification
 - **Description** - specifies part name or description
 - **Quantity (Qty)** - quantity required for assembly
 - **Current Part** - service part numbers are broken down by model, type or other applicable information
 - **Notes** - define unique characteristics or replacement notes
 - **Kits / Assy's Where Used** - indicates Kits or Assemblies that contain a particular part
- **Other pertinent information is listed in tables or parts listings as required.**

Effectively Using a Parts Listing—Example

- Follow the example below to locate and order exactly what is required for servicing.

Match to items on illustration	Use to identify Part	Order this quantity for servicing	Order Part Number by Model indicated		Indicates information important to ordering or use
Item	Description	Qty	DST40(P)	DDT40(P)	Notes
7	Brg Cup - Plain Half	1	129566 •	015092 •	
8	Brg Cone - Plain Half	1	129565 •	128604 •	

Summary of Kits and Assemblies

Item	Description	DST40(P)	DDT40(P)	Notes
	OIL SEAL & SHIM KIT	216224	216224	Includes 49-54 & 127592
	BASIC OVERHAUL KIT	510393	510393	Contents Identified with •

Model Identification

Locating Model Designation Information

- Axle Model Identification, Part Number and Serial Number are located on a tag at the axle centerline. This information will help to locate information in this book and to identify the correct parts for servicing.

Drive Axles

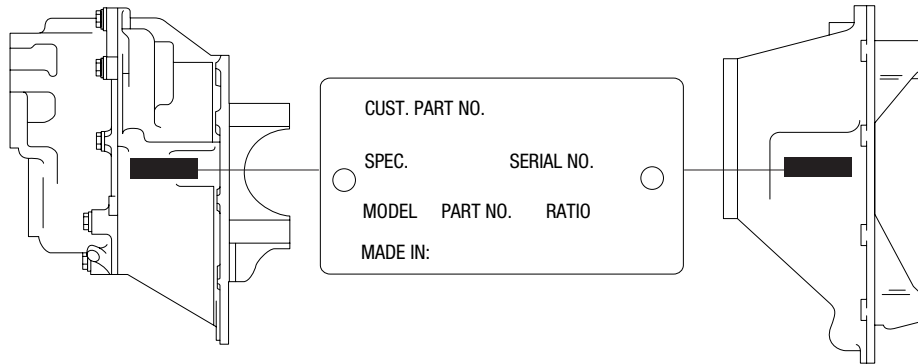

- **Model Number, Part Number and Serial Number** are located on the data plate on the axle centerline

Drive Axle Assembly Tag

1. The OEM part number assigned to the axle build.
2. The specification number assigned to the axle build by Spicer. The spec number will identify all the component parts of the axle as built by Spicer, including special OEM requirements such as yokes or flanges.
3. The axle model identification.
4. The production or service part number of the carrier assembly.
5. The gear ratio of the axle.
6. The serial number of the carrier assembly assigned by the manufacturing plant.

Note: When inquiring about specific information on your axle, write down all of the above information from your tag and call your local OEM dealer or your Dana representative.

7. Country of Origin

- The axles illustrated in this book are specified with a variety of different axle shafts, according to OEM specifications. **When ordering replacement axle shafts, note the part number stamped into the flange.**

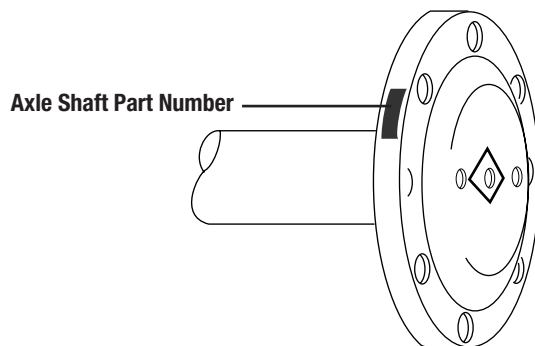

Using Model Designation to Identify Axle Components

- The Axle Model Identification number contains information that is important to understand when purchasing service parts or new components. The Model Identification number provides important vehicle, capacity and application information and model features. Use this guideline to understand your Axle Model Identification. If you need assistance, contact your Dana representative.

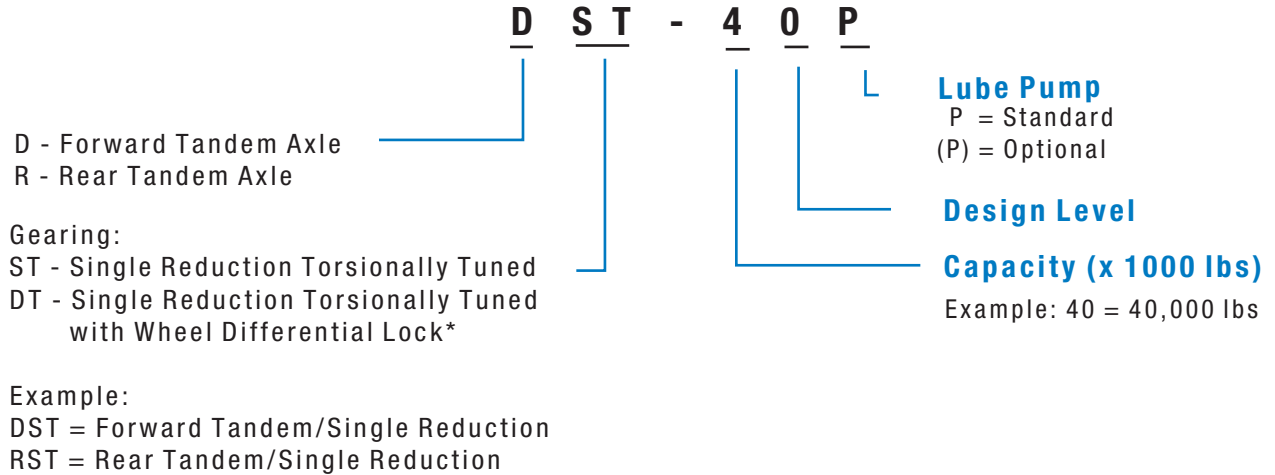

*Wheel Differential Lock is only available on Forward Axles

Forward Axle Parts Explode

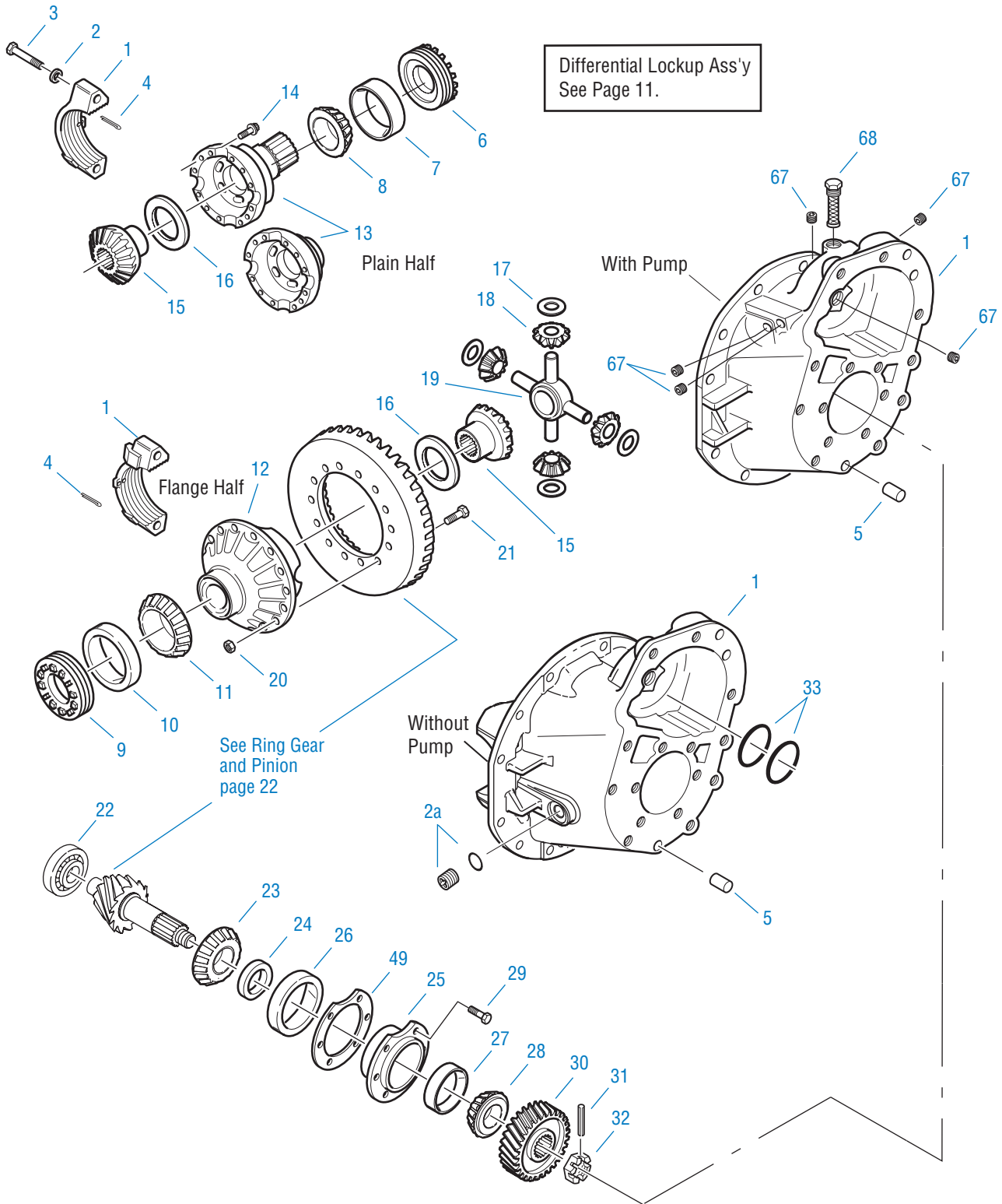

Forward Axle Parts Explode

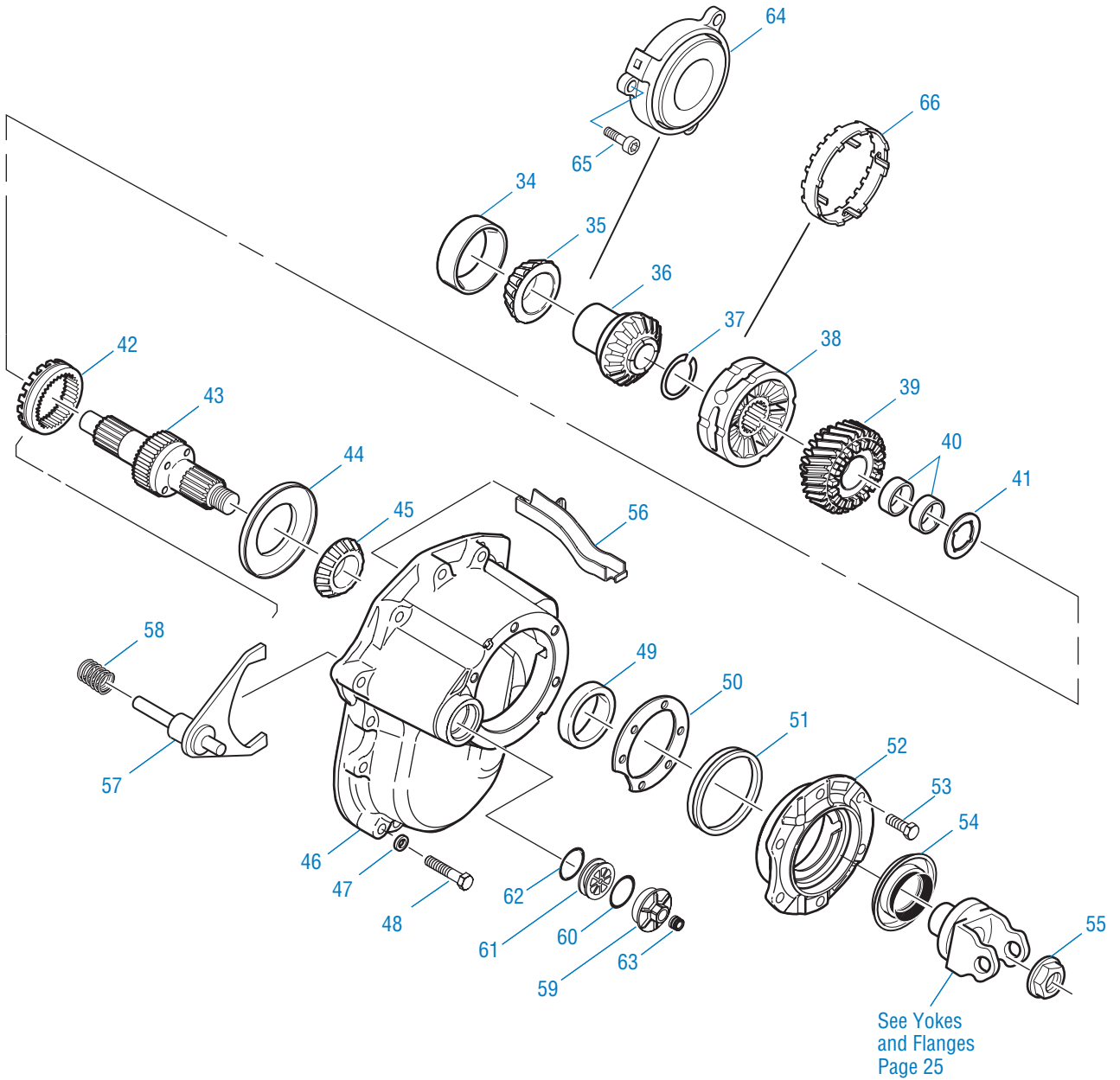

Forward Axle Parts List

Item	Part Name	Qty	DST40(P) DST41(P)	DDT40(P) DDT41(P)	Remarks
	BASIC OVERHAUL KIT		510393	510399	Contents Identified with •
	BEARING KIT		512812	512800	Contents Identified with *
1	DIFF CARRIER & BEARING CAPS KIT				Includes items 1-3, 5, 67, 69-71 and items 8-11 on pg.17
	DST40, 41		510023	--	Casting #130809 or 131810
	DST40P, 41P		510024	--	Casting #130819 or 131825
	DDT40, 41		--	510027	Casting #130814 or 131829
	DDT40P, 41P		--	510028	Casting #130814 or 131827
2	Flat Washer	4	210288	210288	
2a	Plug & O-ring Assembly	1	131809	131809	O-ring not sold seperately
3	Capscrew	4	210095	210095	
4	Cotter Pin	2	090873	090873	
5	Dowel Pin	2	007641	007641	
6	Diff Brg Adjuster - Plain Half	1	129130	128616	
7	Brg Cup - Plain Half	1	129566*	015092*	
8	Brg Cone - Plain Half	1	129565*	128604*	
9	Diff Brg Adjuster - Flange Half	1	129128	129128	
10	Brg Cup - Flange Half	1	129564*	129564*	Optional Part No. 090943
11	Brg Cone - Flange Half	1	129563*	129563*	Optional Part No. 006082
	WHEEL DIFF CASE KITS				Includes items 12-14
12	Diff Case-RH (Flg Half) - NSS129464	1	508653	508724	Ratios 2.64 to 3.25
	NSS129465		508654	508725	Ratios 3.36 to 3.90
	NSS129466		508655	508726	Ratios 4.11 to 4.88
	NSS129467		508656	508727	Ratios 5.29 to 7.17
13	Diff Case-LH (Plain Half)-NSS	1	127498	128607	Order kits listed above
14	Capscrew	12	127465	128619	
	WHEEL DIFF SIDE GEAR KIT		510397	510397	Includes items 15-19
	WHEEL DIFF KIT w/o SIDE GEARS		510396	510396	Includes items 16-19
15	Side Gear 41 Inv spline	2	127368	127368	
16	Side Gear Thrust Washer	2	127386 •	127386 •	
17	Side Pinion Thrust Washer	4	129305 •	129305 •	
18	Side Pinion	4	127364	127364	Optional Part No. 129765
19	Diff Spider	1	127359	127359	Optional Part No. 129599
	RING GEAR NUT & BOLT KIT		508652	508652	Includes items 20-21
20	Nut	16	126216	126216	
21	Bolt	16	129686	129686	

Forward Axle Parts List

Item	Part Name	Qty	DST40(P) DST41(P)	DDT40(P) DDT41(P)	Remarks
22	Pinion Pilot Brg	1	127484*•	127484*•	
23	Pinion Brg Cone - Inner	1	129560*•	129560*•	
24	Pinion Brg Spacer	AR			Pinion Bearing Spacer pg. 15
25	Pinion Brg Cage & Cup Assy Cage #127488C NSS	1	129767	129767	Includes items 25-27
26	Pinion Brg Cup - Inner	1	129561*•	129561*•	
27	Pinion Brg Cup - Outer	1	012495*•	012495*•	
28	Pinion Brg Cone - Outer	1	127535*•	127535*•	
29	Capscrew	6	210115	210115	
30	Pinion Helical Gear	1	127523	127523	
31	Roll Pin	1	118807	118807	
32	Slotted Pinion Nut	1	126182	126182	
33	Output Shaft O-Ring	2	127545 •	127545 •	
34	Output Shaft Brg Cup	1	127536*•	127536*•	
35	Output Shaft Brg Cone	1	110812*•	110812*•	
36	Output Shaft Side Gear	1	127645	127645	
37	Snap Ring	1	085997 •	085997 •	
38	Inter-Axle Diff Assy	1	129771	129771	Replaces 128634
39	Helical Side Gear & Bushing Assy Gear #130906 NSS (Incls item 40)	1	130907	130907	Replaces 127495
40	Helical Gear Bushing	2	129371	129371	Replaces 127543
41	Helical Gear Thrust Washer	1	128702 •	128702 •	
42	Lockout Sliding Clutch	1	127510	127510	
43	INPUT SHAFT KIT Input Shaft 129770 NSS	1	510593	510593	Includes Items 41, 43, 55 Replaces 510394
44	Oil Retainer	1	128700 •	128700 •	
45	Input Shaft Bearing Cone	1	129558*•	129558*•	Replaces 820643
46	PDU Cover	1	130823	130823	Replaced 129572
47	Washer	11	128415	128415	
48	Capscrew Long	11	210091	210091	
49	Bearing Cup	1	1008912	1008912	Optional Part No. 129559

Forward Axle Parts List

Item	Part Name	Qty	DST40(P) DST41(P)	DDT40(P) DDT41(P)	Remarks
	OIL SEAL & SHIM KIT	1	216224	216224	Includes items 50, 54 & 127592 (Item 17 on p. 17)
50	Shim.003	AR	127595 •	127595 •	
	Shim.005		127596 •	127596 •	
	Shim.010		127597 •	127597 •	
	Shim.020		127598 •	127598 •	
	Shim.030		127599 •	127599 •	
51	Oil Seal-V-Ring	1	128703 •	128703 •	
52	Input Brg Cover Assy - #129574C	1	129575	129575	Includes item 48
53	Bearing Cover Cap Screw	6	210115	210115	
54	Oil Seal	1	127591*•	127591*•	
55	Locknut	1	128049	128049	In 510394 Kit (M42x1.5)
56	Lube Trough	1	129577	129577	
	AIR LOCKOUT KIT - COMPLETE	1	510052	510052	Includes items 57- 59, 61- 62
	AIR LOCKOUT REPAIR KIT	1	510053	510053	Includes items 59, 61-62
57	Shift Fork Assy - NSS	1	129856	129856	Order Kit 510870
58	Compression Spring	1	129859	129859	
	SHIFT FORK & COMPRESSION SPRING KIT	1	510870	510870	Includes 57-58
59	Piston Cover Assy	1	129573	129573	Includes Cover #129578 & Item 60
60	O-Ring	1	129579	129579	
61	Piston	1	129580	129580	
62	O-Ring	1	210180	210180	
63	Shipping Plug	1	599792	599792	
64	Lube Pump Assembly	1	127534	127534	Pump Models Only
65	Capscrew	3	127551	127551	Pump Models Only
66	Drive Coupling - Service	1	128628	128628	Pump Models Only
67	Pipe Plug	4	090897	090897	Pump Models Only
68	Filter Screen Assy	1	127649	127649	Pump Models Only
69	Thrust Screw	1	126193	126193	M24X2-6g
70	Jam Nut	1	210184	210184	
71	RTV - Sealant	1	107276S*•	107276S*•	Not Illustrated

Wheel Differential Lock Assembly

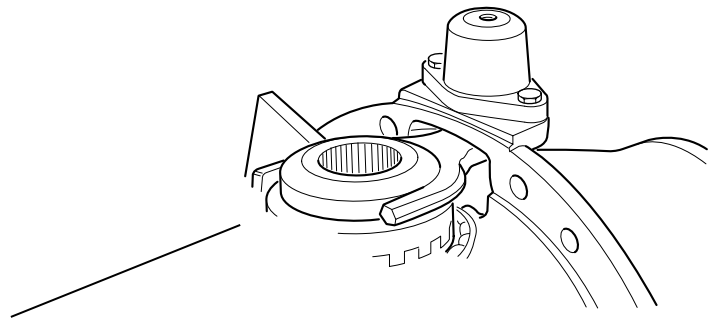
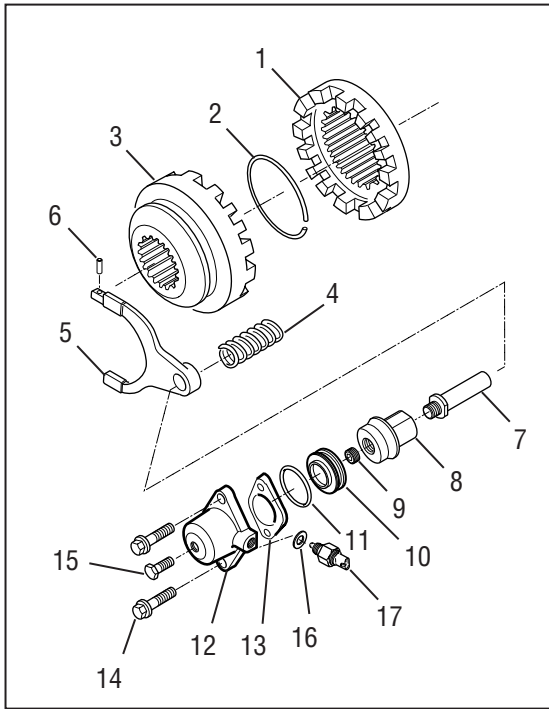

Item	Part Name	Qty	DDT40(P) DDT41(P)	Remarks
1	Fixed Curvic Clutch Gear	1	128627	
2	Snap Ring	1	129433	
3	SL Curvic Clutch Gear - 41 Inv spline	1	126840	
4	Compression Spring	1	128614	
	SHIFT FORK ASSY		217465	Includes items 5-6
5	Shift Fork - 128609 NSS	1		
6	Spring Pin	1	210020	
7	Push Rod	1	128617	
8	Piston Driver	1	128640	
9	Set Screw	1	128618	
10	Piston	1	128624	
11	O-Ring	1	210180	
12	Piston Cover	1	129425	
13	Gasket	1	128643	
14	Capscrew - Flg Head	2	128744	
15	Capscrew	1	128274	M12 x 1.5
16	Washer	1	129034	
17	Switch	1	129035	
18	Wiring Harness, Not Illustrated	1	129047	For Volvo, GM, ITEC, Kenworth & Peterbilt
			129044	For Western Star, Freightliner & Ford
			129046	For Mack

Rear Axle Parts Explode

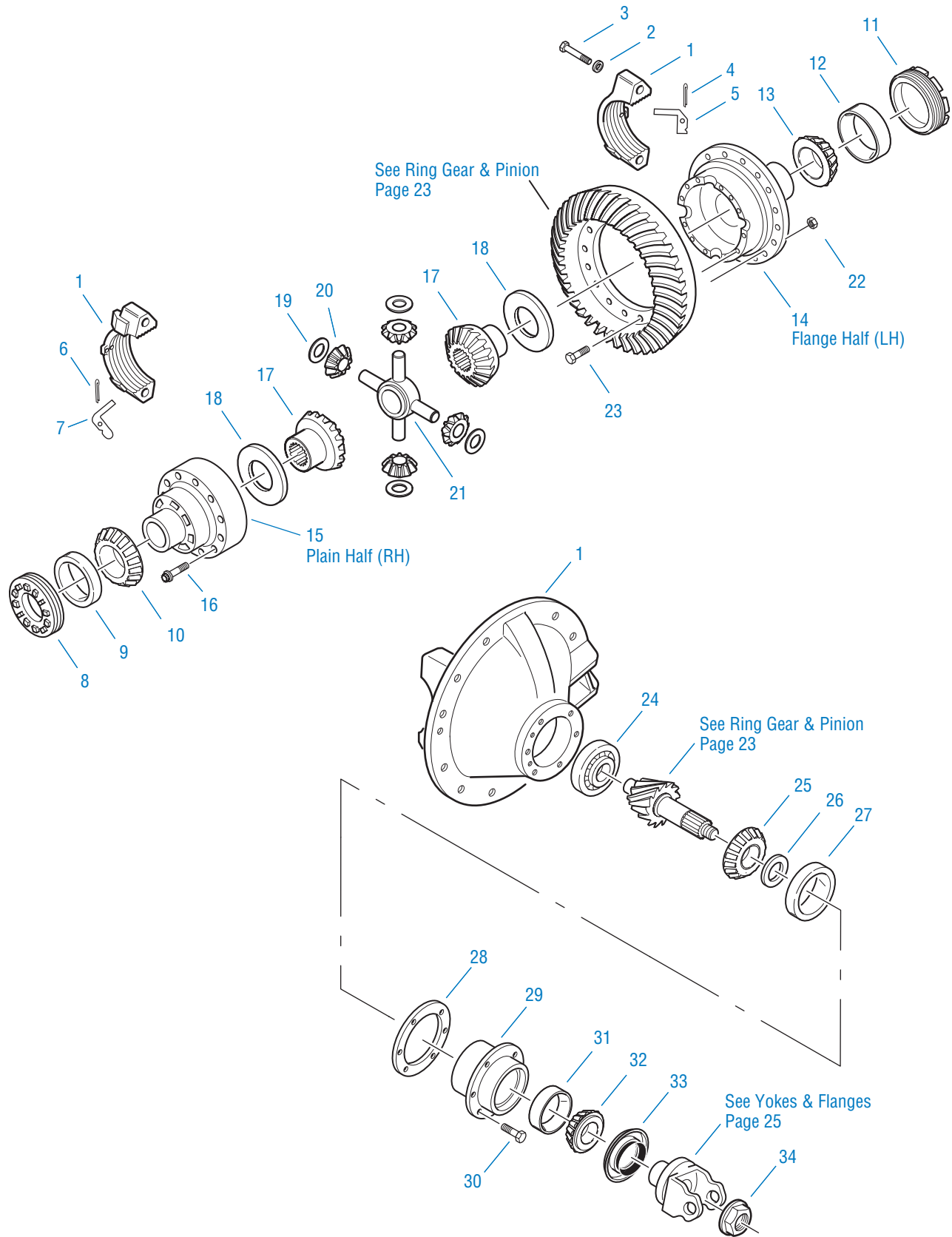

Rear Axle Parts List

Item	Part Name	Qty	RST40, RST41 Prior to 4/1/05	RST40, RST41 After 4/1/05	Remarks
	BASIC OVERHAUL KIT				Contents Identified with •
	Ratios 2.64-5.57		511115	514061	
	Ratios 6.17-7.17		512830	514062	
	BEARING KIT				Contents Identified with *
	Ratios 2.64-5.57		512828	514059	
	Ratios 6.17-7.17		512829	514060	
1	DIFF CARR & BRG CAPS KIT				Includes items 1-3 and items 8-11 on pg. 17
		211219	--		Casting #128109C or127046 See Note 1
		--		514063	Casting # 130945 or 130946
	DIFF CARR & BRG CAPS CONVERSION KIT		--	514064	Casting # 130945, See Note 1
2	Flat Washer	4	210288	210288	
3	Capscrew	4	210095	210095	
4	Cotter Pin - Flange Half	1	090876	090876	
5	Diff Bearing Adj Lock - Flange Half	1	014275	014275	
6	Cotter Pin - Plain Half	1	090873	090873	
7	Diff Bearing Adj Lock - Plain Half	1	013377	013377	
8	Diff Brg Adjuster - Plain Half	1	110243	110243	
9	Bearing Cup - Plain Half	1	129566 •	129566 •	Optional Part No. 009803
10	Bearing Cone - Plain Half	1	129565 •	129565 •	Optional Part No. 027813
11	Diff Brg Adjuster - Flange Half	1	031562	031562	
12	Bearing Cup - Flange Half	1	090943 •	090943 •	Optional Part No. 129564
13	Bearing Cone - Flange Half	1	006082 •	006082 •	Optional Part No. 129563
	WHEEL DIFF. CASE KITS				Includes items 14-16
14	Diff Case-LH (Flg Half)-NSS129984	1	511136	511136	Ratios 2.64 to 3.25
	NSS129985		511137	511137	Ratios 3.36 to 5.29
	NSS129986		511138	511138	Ratios 5.57 to 7.17
15	Diff Case-RH(Plain Half)-NSS	1	129983	129983	Order kits listed above
16	Capscrew	12	096271	096271	
	WHEEL DIFF SIDE GEAR KIT		511139	511139	Includes items 17-21
	WHEEL DIFF KIT w/o SIDE GEARS		511140	511140	Includes items 18-21

Note 1: On 4/1/05, there were several design changes to the RST40 and RST41 models, which are noted below. For additional information, please see Service Bulletin ABIB-0510R1.

- Carrier & Cap Change: The new RST40 and RST41 carrier and cap is unique in its design. The casting number located on the outside edge of the carrier makes it visibly easy to distinguish between old and new design carriers. Order the Carrier & Cap Conversion kit, Part Number 514064, to convert original design models.

514064 Contents		
1	130946	Carrier & Cap
1	129768	Cage & Cup
6	210115	Capscrew
12	130877	Washer
4	130837	Capscrew
8	130836	Capscrew

Rear Axle Parts List

Item	Part Name	Qty	RST40, RST41 Prior to 4/1/05	RST40, RST41 After 4/1/05	Remarks
17	Side Gear 41 Inv spline	2	110527	110527	
18	Side Gear Thrust Washer	2	127386 •	127386 •	
19	Side Pinion Thrust Washer	4	126180 •	126180 •	
20	Side Pinion	4	129690	129690	
21	Diff Spider	1	129999	129999	
	RING GEAR NUT & BOLT KIT		070745	508652	Includes items 22-23
22	Nut	16	060600	126216	See Note 1
23	Bolt	16	067586	129686	See Note 1
24	Pinion Pilot Brg	1			
	2.64-5.57 Ratios		127485 •	127485 •	
	6.17-7.17 Ratios		830398 •	830398 •	Replaces 129175
25	Pinion Brg Cone - Inner	1	045460 •	--	
			--	129562 •	Optional Part No. 014218 See Note 1
26	Pinion Brg Spacer	AR			Pinion Bearing Spacer pg. 15
27	Pinion Brg Cup - Inner	1	129561 •	129561 •	Optional Part No. 014217
	OIL SEAL & SHIM KIT		511169	216225	Includes items 28, 33 and 35
28	Shim.003	AR	107567 •	127595 •	
	Shim.005		107568 •	127596 •	
	Shim.010		107569 •	127597 •	
	Shim.020		107570 •	127598 •	
	Shim.030		107571	127599	
29	Pinion Brg Cage & Cup Assy	1			Includes items 27, 29 & 31, Note 1
	3.55, 3.70 Ratios (See Note 2)		128373	--	Casting #127038R
	All Other Ratios		128372	--	Casting #107495R
	All Ratios		--	129768	Casting #127481C
30	Capscrew	6	113325	--	.562-12
			--	210115	M14X2
31	Pinion Brg Cup - Outer	1	012495 •	012495 •	
32	Pinion Brg Cone - Outer	1	012496 •	012496 •	
33	Oil Seal	1	127591 •	127591 •	
34	Pinion Nut	1	127589	127589	M36 x 1.5
35	RTV - Sealant	1	107276S •	107276S •	Not Illustrated

NSS - Not Sold Separately

Note 1: On 4/1/05, there were several design changes to the RST40 and RST41 models, which are noted below. For additional information, please see Service Bulletin ABIB-0510R1.

- Inner Pinion Bearing Change: Models produced after 4/1/05 require the use of a new inner pinion bearing. The previous inner pinion bearing will not work with the new gear set. The current Gear & Pinion kits include this bearing.
- Pinion Bearing Cage Change: The pinion bearing cage, capscrews and shims were all upgraded to that which is common to the RS404. Carriers made after 4/1/05 have metric threaded pinion bearing cage holes and require the use of 210115 metric-threaded capscrew. This new pinion bearing cage is common to all ratios.
- If you order or rebuild an original axle with the current design gear set you must use the appropriate nut/bolt fasteners.

Note 2: When changing ratios from 3.55 or 3.70 to any other ratio, on early models only, it will require a change in cage & cup part numbers.

Bearing Spacers

DST40(P), 41(P) DDT40(P), 41(P)

Part Number	Spacer Thickness
129079	.797
129080	.798
129081	.800
129082	.801
129083	.802
129084	.803
129085	.804
129086	.806
129087	.807
129088	.808
129089	.809
129090	.810*
129091	.811
129093	.812
129097	.814*
129099	.815*
129101	.816*
129103	.817*
129105	.818*
129107	.819*
129109	.820*
129111	.821*
129113	.822*
129115	.823*
129117	.824*
129119	.825*
129120	.826*
129121	.828*
129122	.829
129123	.830*
129124	.831
129125	.832*
129126	.833

* Most Popular

RST40, 41

Part Number	Spacer Thickness
91552	.623
91553	.624
91554	.625
91555	.626
91556	.627
91557	.628
91558	.629
91559	.630
91560	.631
91561	.632
91562	.633
91564	.634
91566	.635
91568	.636*
91572	.637
91576	.638*
91580	.639*
91584	.640*
91588	.641*
91592	.642*
91596	.643*
91600	.644*
91602	.645*
91604	.646*
91606	.647*
91608	.648*
91610	.649
91611	.650*
91612	.651
91613	.652
91614	.653*
91615	.654*

* Most Popular

Output Shaft & Axle Housing Parts Explode

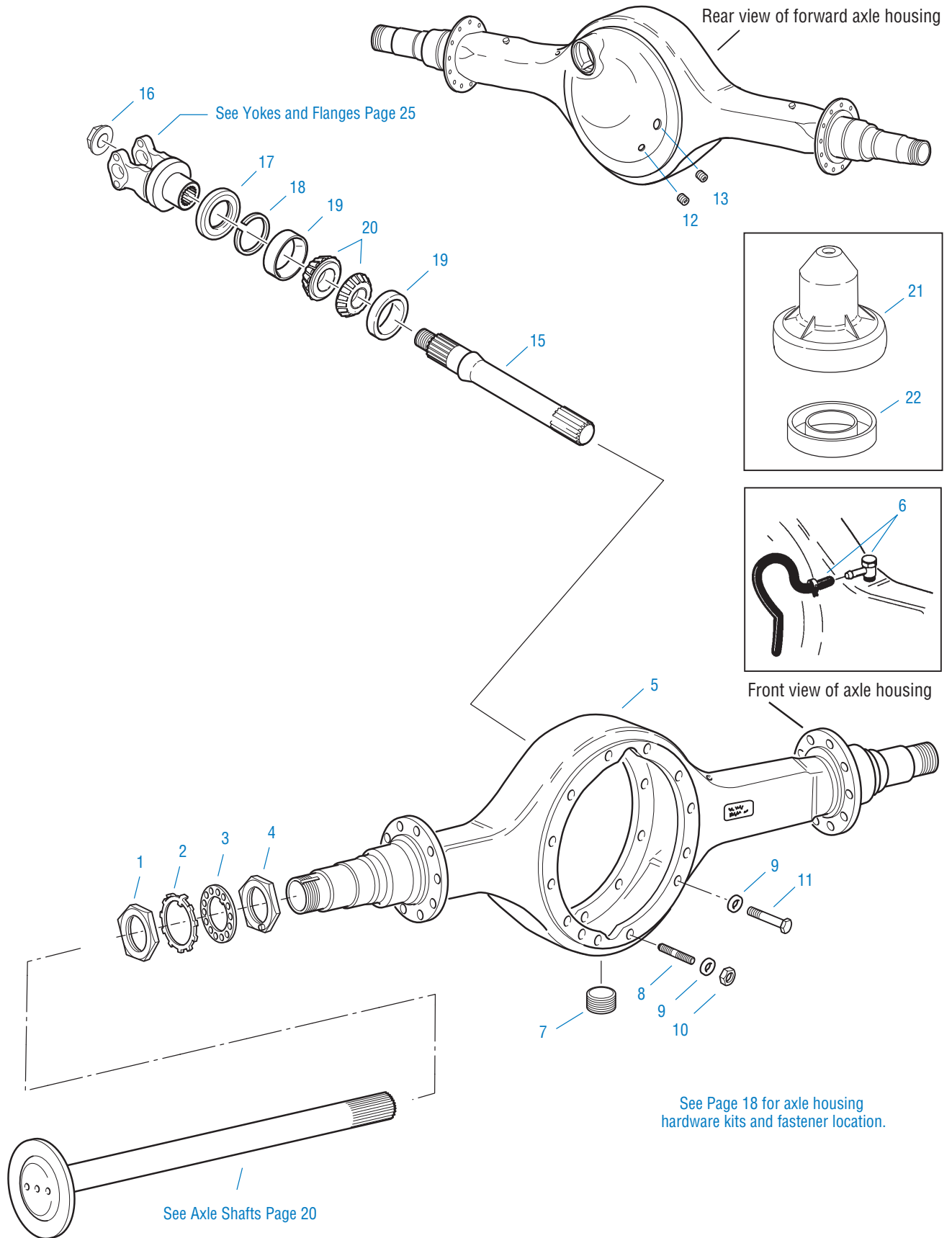

Output Shaft & Axle Housing Parts List

Item	Part Name	Qty	Part Number	Remarks
1	Outer Bearing Adjuster Nut	2	119881	
2	Lockwasher - w/Tab	2	129132	
3	Dowel-Type Lockwasher	2	119883	
4	Inner Bearing Adjuster Nut	2	119882	
5	Axle Housing Assy	1		See your OEM Catalog
6	U-Tube Breather Kit	1	507162	
7	Magnetic Drain Plug - 3/4"	1	54254	All D/R models
8 -11	Carrier to Hsg Fasteners			See Page 18
12	Non-Magnetic Plug 3/4"	1	129492	
12	Magnetic Plug - 3/4"	1	129491	
13	Temperature Sensor Plug 1/2"	1	90898	
14	Lube Tag (for 3/4" Plug)	1	129486	Part - Not Illustrated
	OUTPUT SHAFT KIT	1	216227	Includes Items 16-17
15	Output Shaft - #127646 NSS			
16	Locknut - Hex	1	127588	M39 x 1.5
17	Oil Seal	1	127592	
18	Snap Ring .103"	1	129594	
19	Bearing Cup	2	127539	
20	Bearing Cone	2	127540	
21	Seal Driver	1	126917	In Kit 217414 - See Page 25
22	Adapter	1	128706	In Kit 217414 - See Page 25
23	Loctite Adhesive	1	129293	Not Illustrated, .5 ml Tube
24	RTV - Sealant	1	107276S	Not Illustrated, 3 oz. Tube
	AXLE HOUSING HARDWARE KIT - FORWARD AXLE		512087	
	AXLE HOUSING HARDWARE KIT - REAR-REAR AXLE		514260	For axles manufactured after April 2005
	AXLE HOUSING HARDWARE KIT - REAR-REAR AXLE		514259	For axles manufactured prior to April 2005

NSS - Not Sold Separately

Axle Housing Fasteners - Forward Models

View fastener locations as if installing differential into the axle housing.

Head to Housing Fasteners

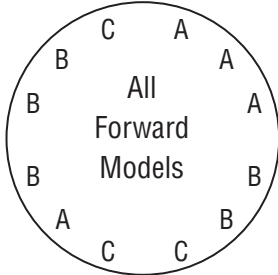

512087 Hardware Kit

Part No.	Qty.	Description
107276S	1	RTV Sealant 3 oz. Tube
130836	8	Capscrew (45 mm) - Short
127567	4	Nut
127641	4	Stud
129293	1	Loctite 271 0.5 ml Tube
130837	4	Capscrew (70 mm) - Long
130877	12	Washer
129193	1	Input Shaft
SHAIS136	1	Instruction Sheet

Axle Housing Fasteners - Rear-Rear Models

On May 1, 2005 the RST40 and RST41 models were upgraded to a new "Thick Flange" carrier design as fully detailed in Spicer bulletin ABIB-0510R1. Shown below are the axle housing hardware kits and fastener locations for both variations. View fastener locations as if installing differential into the axle housing.

Head to Housing Fasteners



A – 127641 Studs & 127567 Nuts
 B – 130836 Capscrews – Short (45 mm)
 C – 130837 Capscrews – Long (70 mm)
 D – 130877 Flat Washers – All Locations

514260 Hardware Kit - Thick Flange (After May 2005)

Part No.	Qty.	Description
107276S	1	RTV Sealant 3 oz. Tube
130836	8	Capscrew (45 mm) - Short
130837	4	Capscrew (70 mm) - Long
130877	12	Washer
054254	1	Magnetic Drain Plug - 3/4"
129491	1	Magnetic Plug - 3/4"
129193	1	Input Shaft
SHAIS172	1	Instruction Sheet - Thick Flange

514259 Hardware Kit - Thin Flange (Prior to May 2005)

Part No.	Qty.	Description
107276S	1	RTV Sealant 3 oz. Tube
090422	4	Lockwasher
090208	4	Nut
054254	1	Magnetic Drain Plug - 3/4"
129491	1	Magnetic Plug - 3/4"
130187	8	Capscrew
068399	1	Stud
036435	3	Stud
129293	1	Loctite 271 0.5 ml. Tube
SHAIS172	1	Instruction Sheet

IMPORTANT!

Spicer does not recommend the mixing of various designs carrier-to-housing capscrews on the same assembly. Whether mixing or not, torques must be measured using a calibrated torque wrench. Failure to re-torque bolts and nuts to proper specifications may lead to carrier to housing leaks and possible component damage.

Axle Shafts

DO NOT MISPLACE AXLE SHAFTS FROM THEIR INTENDED LOCATION.

Note: STR - Straight, TPR - Tapered

Axle Shafts - Forward Models (See Note 1)

Model	Part No.	Qty	Spline	Spline O.D.	Shaft Length	Spline Length	Flange O.D.	Flange Holes	OEM
	127437	1	41	1.87	38.976	4"	8.500	8(.635) STR	1, 2
	127438	1	41	1.87	43.307	4"	8.500	8(.635) STR	1, 2
DST40(P)	128514	1	41	1.87	38.130	4"	8.500	8(.773) STR	3, 4
DST41(P)	128515	1	41	1.87	42.460	4"	8.500	8(.773) STR	3, 4
	128516	1	41	1.87	38.976	4"	8.500	8(.948) TPR	5
	128517	1	41	1.87	43.307	4"	8.500	8(.948) TPR	5

1 = Peterbilt 2 = Freightliner 3 = Volvo 4 = ITEC 5 = Mack

Axle Shafts - Forward Diff Lock Models (See Note 1)

Model	Part No.	Qty	Spline	Spline O.D.	Shaft Length	Spline Length	Flange O.D.	Flange Holes	OEM
DDT40(P)	128514	1	41	1.87	38.130	4"	8.500	8(.773) STR	3
	128559	1	41	1.87	42.460	11"	8.500	8(.773) STR	3
DDT41(P)	128516	1	41	1.87	38.976	4"	8.500	8(.948) TPR	5
	128561	1	41	1.87	43.307	11"	8.500	8(.948) TPR	5

1 = Peterbilt 2 = Freightliner 3 = Volvo 4 = ITEC 5 = Mack

Axle Shafts - Rear Models (See Note 2)

Model	Part No.	Qty	Spline	Spline O.D.	Shaft Length	Spline Length	Flange O.D.	Flange Holes	OEM
RST40	110888	2	41	1.87	41.313	4"	8.500	8(.635) STR	1, 2
RST41	127189	2	41	1.87	41.063	4"	8.500	8(.948) TPR	5
	129332	2	41	1.87	40.690	4"	8.500	8(.773) STR	3, 4

1 = Peterbilt 2 = Freightliner 3 = Volvo 4 = ITEC 5 = Mack

Note 1: Axle shafts are used in "sets", have unequal shaft lengths and may be "location specific" or "Wheel Equipment specific".

Note 2: Axle shafts are equal length for the RST40 and RST41 models.

Axle Shaft Hardware

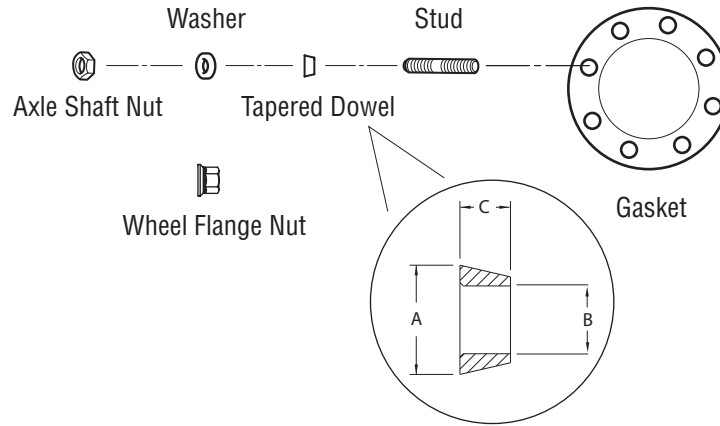

Part Number	Description	Dim. A	Dim. B	Dim. C	Remarks
013885	Tapered Dowel	1.00"	.630"	.469"	For 5/8" studs - Split Dowel
013886	Gasket				8 hole
029804	Washer				
060600	Axle Shaft Nut				5/8", 18 thread
127794	Stud				5/8", 18 thread

Gear & Pinion Kits

Dana has highly developed primary axle gearing which is only used in matched sets. These sets are identified by the mating parts listed below. Within any Dana production drive axle or genuine Spicer® Gear & Pinion service kits, these mated part numbers will appear. Because they are developed as a set with precision machining, never mix gears and pinions from different mated sets within an axle. Shortened gearing life, noise and failure may occur. Always use genuine Spicer® products

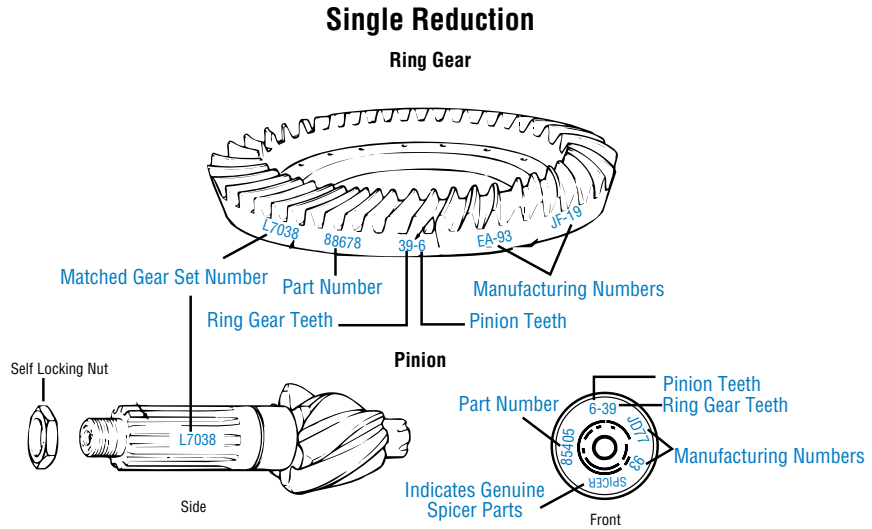

D - Forward Axle DST/DDT40, DST/DDT41

Slotted Pinion Nut Part No. 126182

M42 x 1.5

Ratio	For Service Order Kit Part No.	Mated Gear/Pinion Set		Mated Gear/Pinion Set		Tooth Combo	Ring Gear Size (in.)
		Gear (NSS)	Pinion (NSS)	Gear (NSS)	Pinion (NSS)		
2.64	211462	127387	127439	--	--	37/14	14.90
2.85	211463	127388	127440	132228	132197	37/13	15.40
2.93	509423	129531	129532	132229	132198	41/14	15.40
3.08	513386	127388	129716	132230	132200	37/12	15.40
3.25	513385	127389	130120	132232	132303	39/12	15.40
3.36	513384	127388	130121	132234	132304	37/11	15.40
3.55	513383	127389	130122	132236	132305	39/11	15.40
3.70	513382	127388	130123	132238	132207	37/10	15.40
3.90	513381	127389	130124	132240	132209	39/10	15.40
4.11	513380	127388	130125	132242	132211	37/9	15.40
4.33	513379	130201	130126	132244	132309	39/9	15.40
4.63	513378	130196	129733	132246	132216	37/8	15.70
4.88	513377	130197	129735	132248	132218	39/8	15.70
5.29	513376	130196	129816	132250	132220	37/7	15.70
5.57	513375	130197	129820	132252	132222	39/7	15.70
6.17	513374	127390	129843	132254	132224	37/6	15.70
6.50	211477	127391	127454	132257	132226	39/6	15.40

R - Rear Axle
RST40, RST41
39-1.95" Inv Spline

Pinion Nut Part No. 127589
 M36 x 1.5

Ratio	Service Kit Part No.	Current Mated Gear/Pinion Set (See Note 1)		Original Mated Gear/Pinion Set (See Note 1)		Tooth Combo	Ring Gear Size (in.)
		Gear (NSS)	Pinion (NSS)	Gear (NSS)	Pinion (NSS)		
2.64	513869	131874	131873	--	--	37/14	16
2.93	513870	130947	130949	--	--	41/14	16
3.08	511148	131842	131814	128025	129987	37/12	16
3.25	511149	131843	131815	127886	129988	39/12	16
3.36	511150	131844	131816	120045	129989	37/11	16
3.55	511151	131845	131817	109862	129990	39/11	16
3.70	511152	131846	131818	88013	129991	37/10	16
3.90	511153	131848	131819	99746	129992	39/10	16.5
4.11	511154	131849	131820	86372	129993	37/9	16.5
4.33	511155	131850	131821	86374	129994	39/9	16.5
4.88	512158	131852	131822	86378	130873	39/8	16.5
5.29	512159	131853	131823	86380	130874	37/7	16.5
5.57	512160	131854	131824	86880	130875	39/7	16.5
6.17	512161	131857	131855	130871	130872	37/6	16.5
6.50	512162	131858	131856	86882	129160	39/6	16.5

Note 1: Effective April 1, 2005, drive pinions for the RST40 and RST41 models were redesigned. The new design requires the use of a new inner pinion bearing, part number 129562. This bearing is included with all RST40 and RST41 service gear sets. For additional information on these changes, please see Service Bulletin ABIB-0510R1.

- Current model gear sets are designed to use ring gear bolt part number 129686 and nut part number 126216, which are sold in Service Kit 508652. Use this kit for axles manufactured after April 1, 2005 or if you are rebuilding an axle with an "original" design gear set.
- Original design gear sets, used in models built prior to April 1, 2005, use ring gear bolt part number 67586 and nut part number 60600, which are sold in Service Kit 70745. When rebuilding an axle with a current design gear set you must use the appropriate nut/bolt fasteners.

Service Carriers - Single Reduction

DST40(P), DST41(P)

Ratio	Spline	Non-Pump	Pump
2.64	41 Inv	674861	675200
2.85	41 Inv	674862	675201
2.93	41 Inv	675634	676114
3.08	41 Inv	674863	675202
3.25	41 Inv	674864	675203
3.36	41 Inv	674865	675204
3.55	41 Inv	674866	675205
3.70	41 Inv	674867	675206
3.90	41 Inv	674868	675207
4.11	41 Inv	674869	675208
4.33	41 Inv	674870	675209
4.63	41 Inv	674871	675210
4.88	41 Inv	674872	675211
5.29	41 Inv	674873	675212
5.57	41 Inv	674874	675213
6.17	41 Inv	674875	675214
6.50	41 Inv	674876	NA

Note: Model ID tag may read DS404(P) or DS405(P).

DST40 (P), DST41(P) with No Spin

Ratio	Spline	Non-Pump	Pump
5.29	41 Inv	NA	508473
6.50	41 Inv	NA	508390

DDT40(P), DDT41(P) - Diff Lock

Ratio	Spline	Non-Pump	Pump
2.64	41 Involute	675510	675303
2.85	41 Involute	675251	675304
3.08	41 Involute	675252	675305
3.25	41 Involute	675253	675306
3.36	41 Involute	675254	675307
3.55	41 Involute	675255	675308
3.70	41 Involute	675256	675309
3.90	41 Involute	675257	675310
4.11	41 Involute	675258	675311
4.33	41 Involute	675259	675312
4.63	41 Involute	675260	675313
4.88	41 Involute	675261	675314
5.29	41 Involute	675262	675315
5.57	41 Involute	675263	675316
6.17	41 Involute	675264	675317
6.50	41 Involute	675265	675318

Note: Model ID tag may read DD404(P) or DD405(P).

RST40, RST41

Ratio	Spline	Service Carrier	Notes
2.64	41 Inv	676134	
2.93	41 Inv	676140	
3.08	41 Inv	675904	
3.25	41 Inv	675905	
3.36	41 Inv	675906	
3.55	41 Inv	675907	
3.70	41 Inv	675908	
3.90	41 Inv	675909	
4.11	41 Inv	675910	
4.33	41 Inv	675911	
4.88	41 Inv	676116	
5.29	41 Inv	676117	
5.57	41 Inv	676118	
6.17	41 Inv	676119	
6.50	41 Inv	676120	

Yokes & Flanges

Spicer yoke part numbers shown below are PRODUCTION part numbers and are for reference only. The part numbers needed for service may vary. Please contact Driveshaft Division for price and availability of service yokes. For additional information, see Service Bulletin ABIB0607.

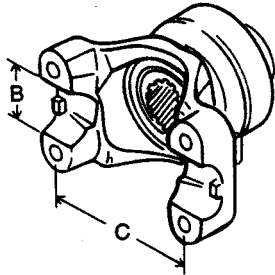

**Style X
Half Round**

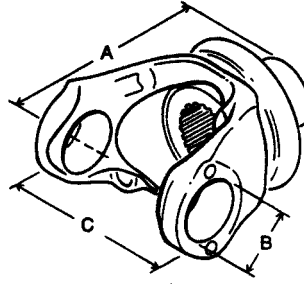

**Style Y
Full Round**

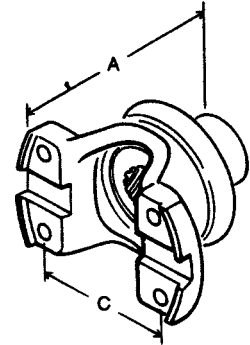

**Style Z
Half Round
Tapped Holes
Bearing Strap**

DST40/RST40 Series

Forward Axle - Input / 44-2.25 Inv Spline

Yoke & Slinger	Series	Joint Angle	Style	Dim. A	Dim. B	Dim. C	Vendor P/N
210801	92N	N/A	Comp.	4.03	-----	-----	92NYS36-75A
210831	SPL170	25	X	5.27	2.17	6.46	170-4-201-1X
210833	SPL250	25	X	5.49	2.36	6.42	250-4-81-1X
210869	RPL25	24	X	4.81	-----	8.36	25WYS36-1A

Forward Axle - Output / 39-1.95 Inv Spline

Yoke & Slinger	Series	Joint Angle	Style	Dim. A	Dim. B	Dim. C	Vendor P/N
210805	92N	31	Comp.	4.38	-----	-----	92NYS32-35A
210835	SPL170	25	X	5.27	2.17	6.46	170-4-221-1X
210837	SPL170	45	X	6.50	2.17	6.46	170-4-241-1X
210871	RPL20	30	X	5.38	-----	7.06	20WYS32-7A
210873	RPL20	42	X	5.94	-----	7.06	20WYS32-8A

Rear Axle - Pinion / 39-1.95 Inv Spline

Yoke & Slinger	Series	Joint Angle	Style	Dim. A	Dim. B	Dim. C	Vendor P/N
210809 - NLA	92N	31	Comp.	4.29	-----	-----	
210839	SPL170	25	X	5.16	2.17	6.46	170-4-261-1X
210841	SPL170	45	X	6.24	2.17	6.46	170-4-281-1X
210875	RPL20	30	X	4.85	-----	7.06	20WYS32-5A
210877	RPL20	42	X	5.69	-----	7.06	20WYS32-6A

Oil Seal Installation Tools

This kit contains installation tools used for installing drive axle oil seals. Using these tools ensures proper installation of the seal. Failure to use these tools may results in an improperly installed or damaged seal.

Oil Seal Driver Installation Kit 217414

D-Input

Use 126917

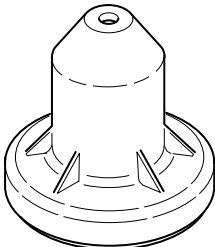

126917

D-Output

Use 126917 and 128706

126917

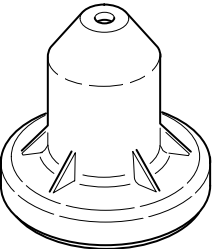

+

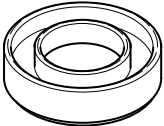

128706

R-Pinion

Use 126917

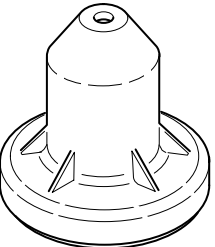

126917

Description	Part Number
Air Lockout Kit - Complete	510052
Air Lockout Repair Kit	510053
Axle Hsg Breather Kit	507162
Axle Hsg Hardware Kit	
All Forward Models	512087
RST40, RST41 Thick Flange - After 4/1/05	514260
RST40, RST41 Thin Flange - Prior to 4/1/05	514259
Basic Overhaul Kits	
DST40(P), DST41(P)	510393
DDT40(P), DDT41(P)	510399
RST40, RST41, ratios 2.64-5.57, Prior to 4/1/05	511115
RST40, RST41, ratios 2.64-5.57, After 4/1/05	514061
RST40, RST41, ratios 6.17-7.17, Prior to 4/1/05	512830
RST40, RST41, ratios 6.17-7.17, After 4/1/05	514062
Bearing Kits	
DST40(P), DST41(P)	512812
DDT40(P), DDT41(P)	512800
RST40, RST41, ratios 2.64-5.57, Prior to 4/1/05	512828
RST40, RST41, ratios 2.64-5.57, After 4/1/05	514059
RST40, RST41, ratios 6.17-7.17, Prior to 4/1/05	512829
RST40, RST41, ratios 6.17-7.17, After 4/1/05	514060
Diff Carrier & Bearing Caps Kits	
DST40, DST41	510023
DST40(P), DST41(P)	510024
DDT40, DDT41	510027
DDT40(P), DDT41(P)	510028
RST40, RST41, Prior to 4/1/05	211219
RST40, RST41, After to 4/1/05	514063
Diff Carrier & Bearing Caps Conversion Kit	514064
Input Shaft Kit	510593

Description	Part Number
Oil Seal Driver Installation Kit	217414
Oil Seal Shim Kits	
DST40(P), DST41(P), DDT40(P), DDT41(P)	216224
RST40, RST41, Prior to 4/1/05	511169
RST40, RST41, After 4/1/05	216225
Output Shaft Kit	216227
Ring Gear Nut & Bolt Kit	
Forward axles	508652
Rear axles manufactured after 4/1/05	508652
Rear axles manufactured prior to 4/1/05	70745
Shift Fork & Compression Spring Kit	510870
Wheel Diff Case Kits	
DST40(P), DST41(P) - Ratios 2.64 to 3.25	508653
DST40(P), DST41(P) - Ratios 3.36 to 3.90	508654
DST40(P), DST41(P) - Ratios 4.11 to 4.88	508655
DST40(P), DST41(P) - Ratios 5.29 to 7.17	508656
DDT40(P), DDT41(P) - Ratios 2.64 to 3.25	508724
DDT40(P), DDT41(P) - Ratios 3.36 to 3.90	508725
DDT40(P), DDT41(P) - Ratios 4.11 to 4.88	508726
DDT40(P), DDT41(P) - Ratios 5.29 to 7.17	508727
RST40, RST41 - 2.64 to 3.25	511136
RST40, RST41 - 3.36 to 5.29	511137
RST40, RST41 - 5.57 to 7.17	511138
Wheel Diff Side Gear Kit	
DST40(P), DST41(P), DDT40(P), DDT41(P)	510397
RST40, RST41	511139
Wheel Diff Kit less Side Gears	
DST40(P), DST41(P), DDT40(P), DDT41(P)	510396
RST40, RST41	511140

For specifying or service assistance, call 1-877-777-5360 or visit our website at www.dana.com

Dana Commercial Vehicle Products Group

3939 Technology Drive
Maumee, Ohio, USA 43537

www.dana.com



SPICER[®]

Drivetrain Products